

nEXT TURBOMOLECULAR PUMPS

Giving you a clear edge

Ideal
vacuum products

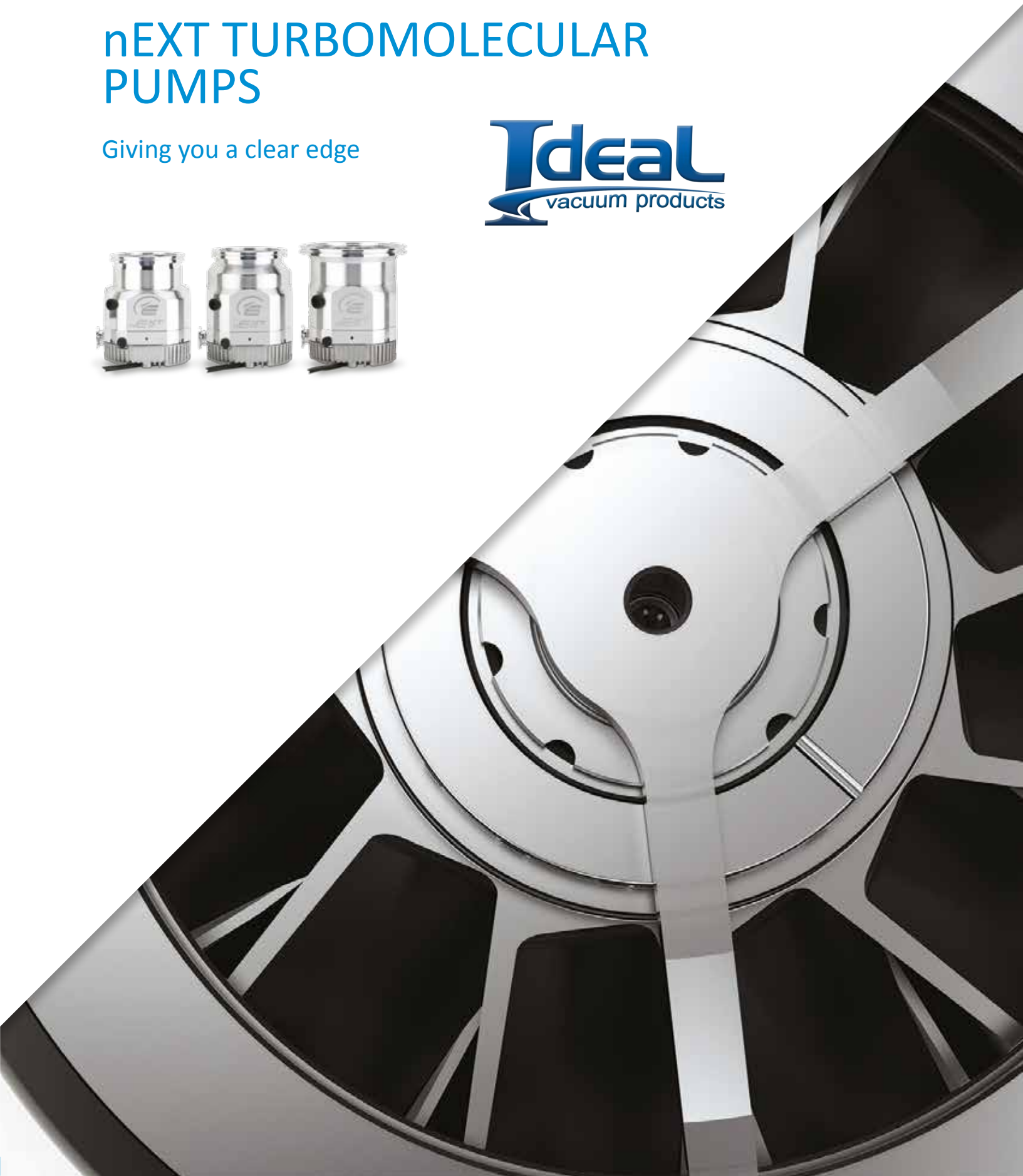



EDWARDS THE PARTNER OF CHOICE

Edwards is a world leader in the design, technology and manufacture of vacuum pumps with over 95 years' history and more than 75 years' manufacturing experience.

Edwards believes in delivering results that bring value to our customers by using our breadth of industry experience to identify and apply solutions to your problems. Using the most innovative and up-to-date modelling techniques, we can optimise the pumping configuration for customers to provide a system design giving the maximum performance in the most reliable and cost-effective way.

PERFORMANCE YOU CAN RELY ON

Edwards nEXT is the ultimate experience in turbomolecular pumps

nEXT turbomolecular pumps are built on decades of experience and are based on our tried and trusted EXT and STP ranges. nEXT pumps offer superior performance, reliability and end user serviceability, setting the benchmark for scientific turbomolecular pumps.

Exceptional pumping speeds and compression ratios
Superior Performance

Huge install base of turbo pumps
Proven reliability for peace of mind

Bespoke options available for OEMs
Customised solutions

Intelligent controls
Flexibility of operation

End user serviceable
Extended lifetime and low cost of ownership

Applications

You can be assured Edwards has the application expertise and vacuum solution to meet your needs.

Mass spectrometry

- GCMS, LCMS, ICPMS, MALDI, inorganic MS, RGA, surface science, leak detectors

Electron microscopy

- TEM, SEM, EPMA, sample prep benches

Research and development

- Chamber evacuation, coating systems, turbomolecular pump systems

High energy physics

- Beam Lines, accelerators, mobile pump carts, turbomolecular pump backing, laser evacuation, medical systems

Industrial

- Glove boxes, coating systems, XRD/XRF systems, lamp evacuation

nEXT turbomolecular pumps sectional view

The compact design allows for close pitch positioning in multiple pump installations. Backwards compatible with existing EXT and DX ranges offering superior performance in a smaller space envelope. Compatible with Edwards TIC Controllers.

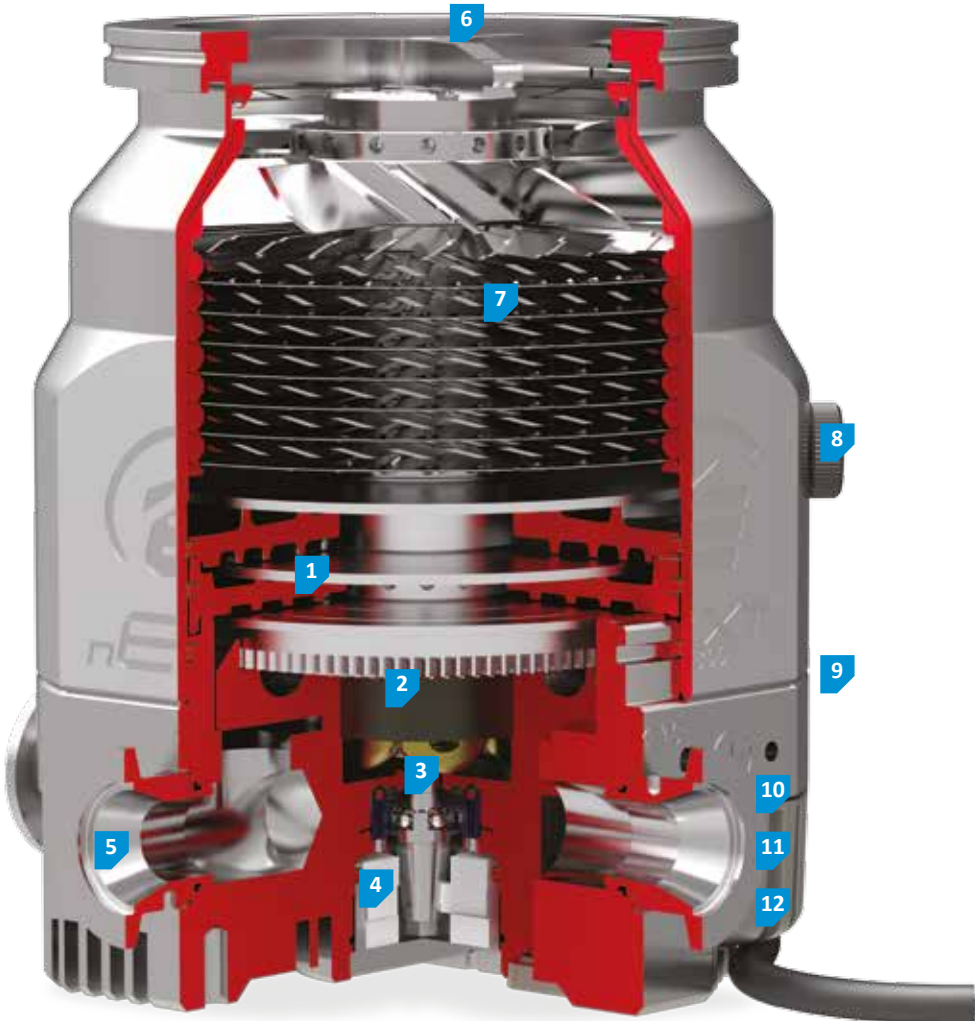

- 1 Multiple drag stages for higher compression ratios and greater backing pressure tolerance
- 2 Sensorless drive for high efficiency and compactness with reduced stray magnetic fields
- 3 Patented bearing suspension system minimises noise and vibration transmitted to vacuum system
- 4 User replaceable oil cartridge for a speedy interim service
- 5 Regenerative stage 'Boost' port option for reduced pump numbers in differentially pumped systems for maximum system rationalisation
- 6 Permanent magnet upper bearing for a hydrocarbon free vacuum, reduced vibration and minimum wear
- 7 Advanced simulation tool derived rotor design to give better speed and compression performance
- 8 Manual vent port with automatic valve accessories for rapid venting and quick cycle times
- 9 Purge port for safe operation of pump with specialised gases
- 10 Manual as well as serial setting of standby speed for flexible system tuning
- 11 Simple parallel operation or more sophisticated serial control in both RS232 and RS485 protocols
- 12 Automatic wide operating voltage range from 24V to 48V dc for versatility in system integration



Advanced technology

nEXT has been designed to combine all the latest technological advances in turbo pumps with some new thinking in design for manufacture, delivering a truly class leading product to market.

nEXT is available in three sizes

- **nEXT240**
*DN100 ISO-K or
DN100 ISO CF*
- **nEXT300**
*DN100 ISO-K or
DN100 ISO CF*
- **nEXT400**
*DN160 ISO-K or
DN160 ISO CF*

The pump name refers to the true peak pumping speed for nitrogen gas.

The nEXT platform brings a high level of modularity to offer maximum flexibility for customer application and requirements. Each pump is available in two different internal configurations to offer differing performance.

Duplex “D” variants with both turbomolecular and drag stages for improved tolerance to higher backing line pressures.

Triplex “T” variants feature turbo, drag and Edwards unique fluid dynamic stages for the ultimate in compression ratio and boost technology for maximum vacuum system rationalisation.



nEXT240
*DN100 ISO-K or
DN100 ISO CF*

nEXT300
*DN100 ISO-K or
DN100 ISO CF*

nEXT400
*DN160 ISO-K or
DN160 ISO CF*

Boost technology

The “T” variants of nEXT employ a unique viscous pumping stage which can be used to ‘boost’ the performance of the backing pump. This offers a much simplified vacuum solution with greatly improved pumping speeds and system power reduction. The example in the image to the right shows how the boost ports can be used to replace a primary pump on a differentially pumped system.

To take maximum advantage of boost technology, please contact Edwards.

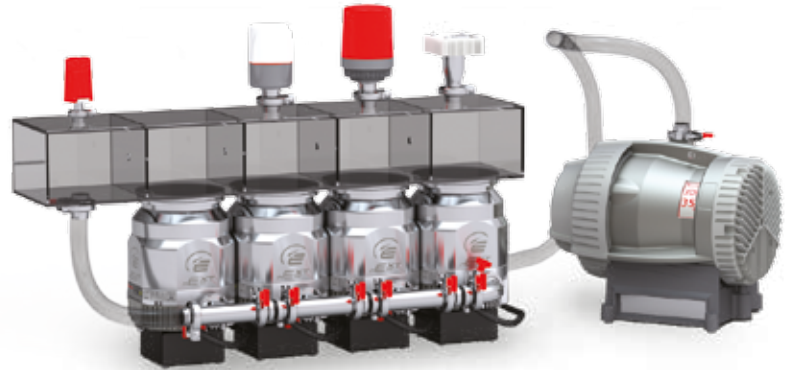

Service

New technologies employed in nEXT have enabled the pumps to be serviced by the end user in the field. An interim oil lubrication change can be performed in situ, where access allows, typically in less than 5 minutes with the minimum of specialist tooling. This simple intervention will greatly extend the lifetime of the pump in the field.

nEXT turbomolecular pumps will advise the user when a service is due and what level of intervention is required. The user is alerted to a service request by a simple flashing LED sequence on the pumps and by serial comms notification.

Flexibility is again key as these simple services can be performed either by the end user, on site by an Edwards Field Service Technician, or the pump can be returned to an Edwards service hub.

Using remote diagnostics, a user can interrogate the pump to determine how long it is to the next service so that a proactive approach to preventative maintenance can be planned.



Technical data

		nEXT240	nEXT300	nEXT400
Inlet flange		DN100 ISO-K or DN100CF	DN100 ISO-K or DN100CF	DN160 ISO-K or DN160-CF
Inlet pumping speed (l/s)	N ₂	240	300	400
	He	230	340	390
	H ₂	165	280	325
Compression ratio (D)	N ₂	>1 x 10 ¹¹	>1 x 10 ¹¹	>1 x 10 ¹¹
	He	3 x 10 ⁵	1 x 10 ⁶	1 x 10 ⁸
	H ₂	1 x 10 ⁴	5 x 10 ⁴	5 x 10 ⁵
Compression ratio (T)	N ₂	>1 x 10 ¹¹	>1 x 10 ¹¹	>1 x 10 ¹¹
	He	1 x 10 ⁶	3 x 10 ⁶	>1 x 10 ⁸
	H ₂	1.5 x 10 ⁴	1 x 10 ⁵	1 x 10 ⁶
Interstage pumping speed (l/s)	N ₂	13	13	13
	He	13	13	13
	H ₂	11	11	11
Backing/interstage/boost ports		NW25	NW25	NW25
Vent/purge port		1/8" BSPP	1/8" BSPP	1/8" BSPP
Critical backing pressure (D) (mbar)		9.5	9.5	10
Critical backing pressure (T) (mbar)		20	20	20
Maximum continuous inlet flow (nitrogen, sccm)				
Water cooling (40°C ambient)		45	95	105
Forced air cooling (35°C ambient)		30	115	90
Natural convection (30°C ambient)		10	35	45
Maximum system flange temperature during bakeout (CF only)				
Water cooled/forced air cooled		120 / 115°	120 / 115°	120 / 115°
Maximum continuous backing pressure (mbar)				
Water cooling (40°C ambient)		6	6.8	7.5
Forced air cooling (35°C ambient)		4.8	7	7.5
Natural convection (30°C ambient)		1	2.8	4
Recommended backing pump*		RV12/nXDS10i	RV12/nXDS10i	RV12/nXDS10i
Peak booster speed m ³ h ⁻¹ (T variants)				
RV12	N ₂	26	26	26
nXDS10i	N ₂	24	24	24
Normal rotational speed (rpm)		60,000	60,000	60,000
Start time to 90% speed (sec) D (T)		115 (150)	145 (190)	180 (210)
Sound pressure level at 1 m (dBA)		<45 (+/-3)	<45 (+/-3)	<45 (+/-3)
Mass (kg) D (T)	ISO	5.7 (6)	5.7 (6)	6.5 (6.8)
	CF	8.8 (9.1)	8.5 (8.8)	9.5 (9.8)

* a smaller backing pump may be used depending on application.

Performance Curves

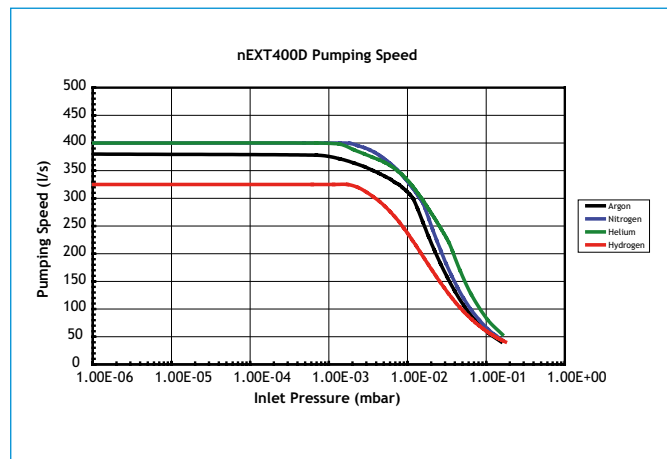
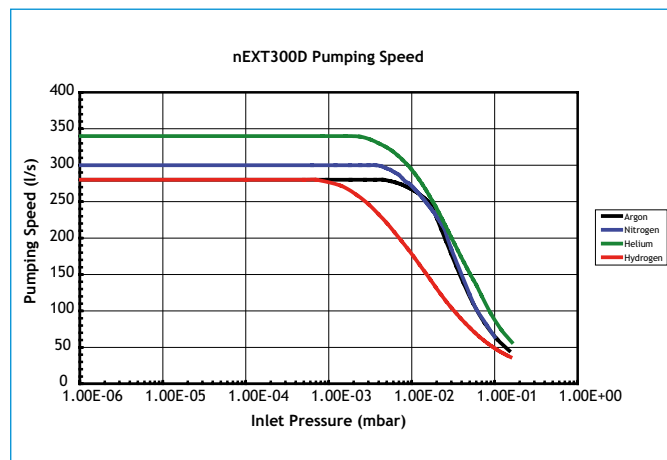
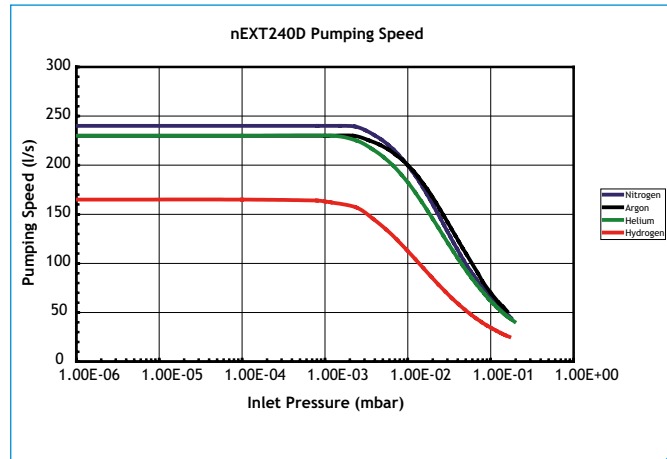

Dimensions

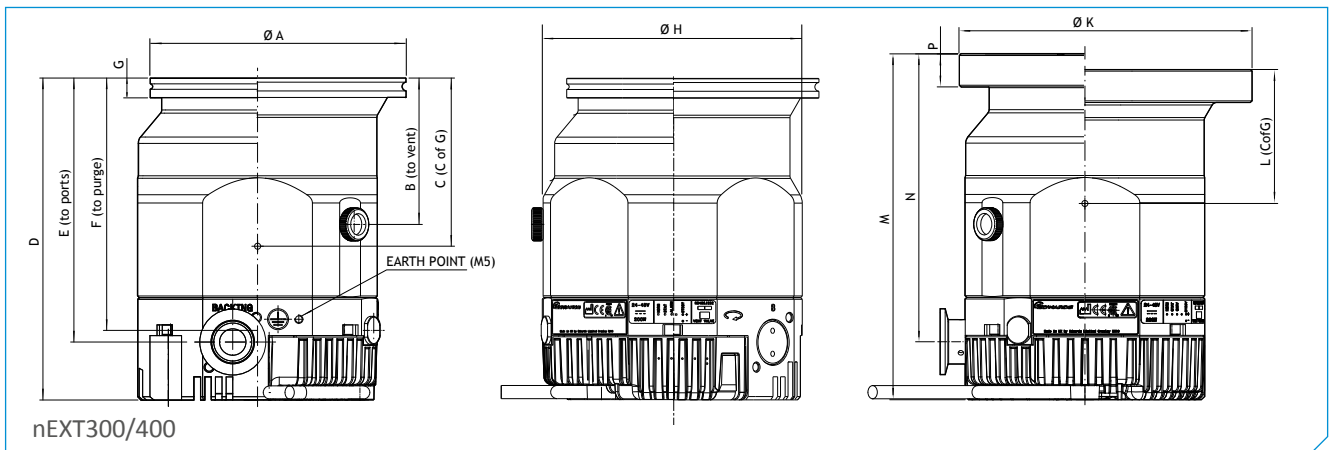
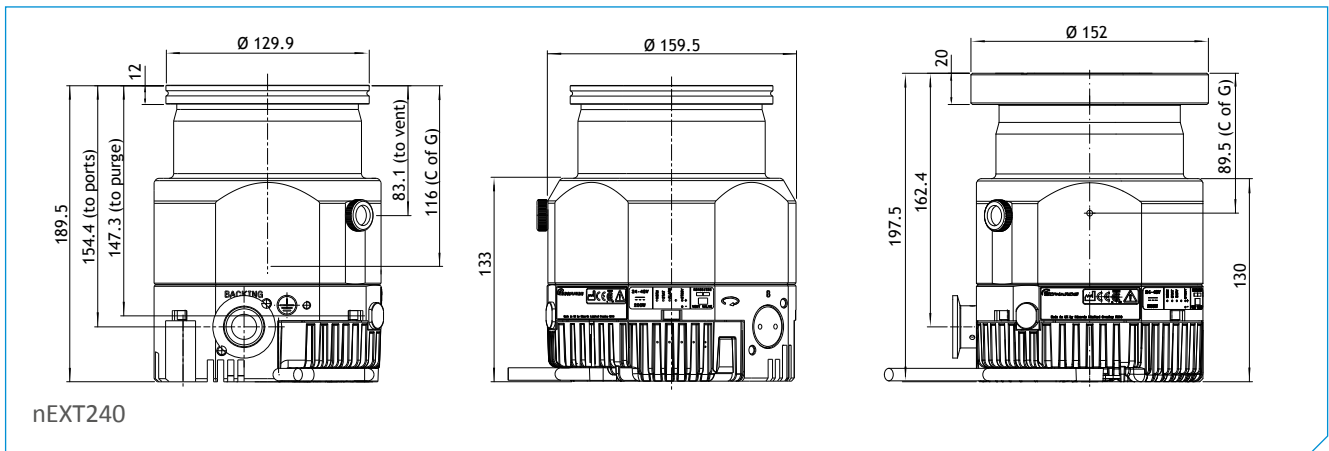
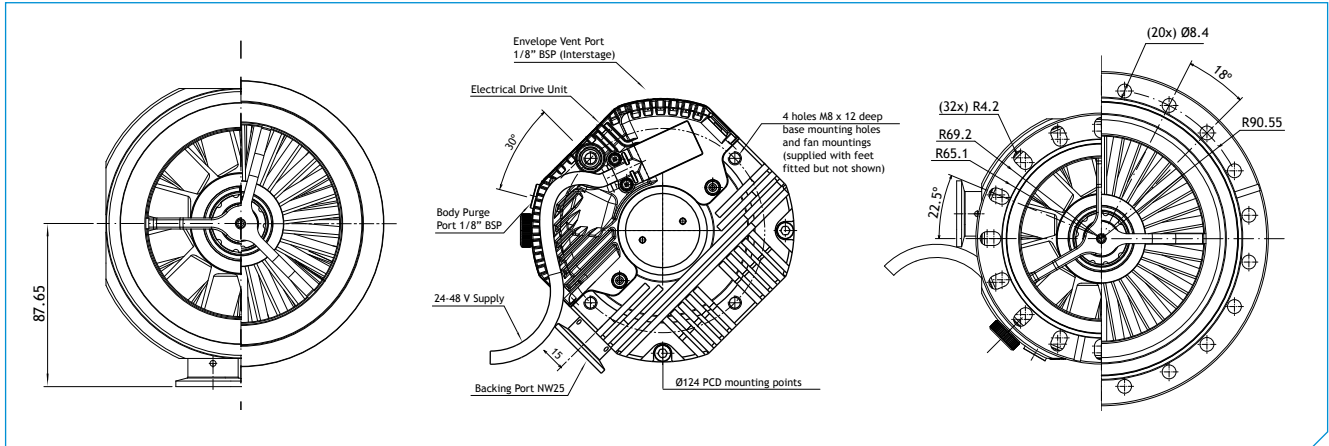

	A	B	C	D	E	F	G	H	J	K	L	M	N	P
nEXT300	129.9	88.7	117	195	159.5	152.8	12	159.9	87	152	81.1	200	164.9	20
nEXT400	179.9	88.7	102	195	159.5	152.8	12	159.9	87	202.4	100.4	209.5	174.4	20

Controllers and accessories



The **TIC (Turbo and Instrument Controller)** automatically recognises and supports one turbo-molecular pump from the nEXT range, plus three Edwards active gauges. Cooling and vent valve support is provided directly from the controller. Backing pump power is provided for a compact 24V diaphragm pump (on 200W versions only), or where greater pumping speeds are required, mains backing pumps (up to RV12) may be controlled via an optional relay box.

nXDS and large XDS pumps can be controlled directly via the backing pump connector on a TIC 200. The relay box can also be used to control a mains heater band and backing line isolation valve. Time delays and normal speed signals may be used to control events such as turbo start and there is a comprehensive selection of protection and safety interlock features. The TIC turbo controller may be either rack or bench mounted and provides a useful hub for the flexible operation of a wide range of vacuum system configurations.

The **TAG (Turbo and Active Gauge) controller** is a small, compact, low cost pumping system controller, which is suitable for a wide range of vacuum applications. It is a 24V controller that is compatible with all Edwards DX and nEXT turbomolecular pumps. It contains no power source and therefore you either need to supply your own power or buy the optional power supply. In addition to a turbomolecular pump it can control a backing pump, a vent valve, an air cooler and an Edwards active gauge. The TAG Controller is controlled by an easy to use interface. A large clear LED display shows the pump speed or vacuum pressure. The compact size of the controller is ideal for use on bench-tops or suitable mobile platforms.



Selection of common accessories - for full list, please contact Edwards or visit our website.

Order No.	Description	Order No.	Description
D39721000	TIC (Turbo & Instruments) 100 W	D39592000	TAG Turbo and Active Gauge Controller
D39722000	TIC (Turbo & Instruments) 200 W	D39592800	200 W power supply
B58066010	TAV 5 Vent Valve	D39700835	Turbo extension cable 1 m
B58066020	TAV 6 Vent Valve	D39700836	Turbo extension cable 2 m
B58053175	nEXT Radial Fan	D39700837	Turbo extension cable 5 m
B58053185	nEXT Axial Fan		
B80000815	nEXT Water Cooling Block		

Ordering information

Selection of common part numbers.

Description		Order No.	Order No.
Pump	Flange	Max power - 80W	Max power - 160W
nEXT240D	DN100 ISO-K	B81200101	B81200100
	DN100 ISO-CF	B81200201	B81200200
nEXT300D	DN100 ISO-K	B82200101	B82200100
	DN100 ISO-CF	B82200201	B82200200
nEXT400D	DN160 ISO-K	B83200301	B83200300
	DN160 ISO-CF	B83200401	B83200400

Note that all nEXT turbomolecular pumps are supplied with a coarse inlet screen. Fine grade screens are available upon request. Interstage and/or T variants both with selectable port positions available upon request.

EDWARDS GLOBAL CONTACTS



EUROPE

UK Crawley +44 1293 528844

UK (local rate) 08459 212223

Belgium Brussels +32 2 300 0730

France Paris +33 1 4121 1256

Germany Munich 0800 000 1456

Italy Milan +39 02 48 4471

USA

Niagara (toll free) +1 800 848 9800

BRAZIL

Sao Paulo +55 11 3952 5000

ISRAEL

Qiryat-Gat +972 8 681 0633

ASIA PACIFIC

China (toll free) +86 400 111 9618

India Pune +91 20 4075 2222

Japan Yachiyo +81 47 458 8831

Korea Bundang +82 31 716 7070

Singapore +65 6546 8408

Taiwan R.O.C. Jhunan Town +886 3758 1000

Publication Number: B80000895 issue C
© Edwards Limited 2015. All rights reserved.
Edwards and the Edwards logo are trade marks of Edwards Limited.

Whilst we make every effort to ensure that we accurately describe our products and services,
we give no warranty as to the accuracy or completeness of any information provided in this brochure.
Edwards Ltd, registered in England and Wales No. 6124750, registered office: Manor Royal, Crawley, West Sussex RH10 9LW, UK

edwardsvacuum.com

